



**Dedicated
Serving
System**

DS-CW-V5

Cold Food Drop-in Well

General Specifications & Features

- Refrigerated drop-in display unit with self-contained compressor, utilizing R-134a refrigerant.
- BTU load: 1151
- Self-contained compressor: 1/3 HP
- Refrigeration mode: static cooling
- System is mounted on corrosion resistant framework, suspended below unit body.
- Operating refrigerator temperature at +5 / +8°C.
- Digital thermostat provides cold holding temperature flexibility.
- #304 Stainless steel interior & exterior.
- Insulated with CFC free, foamed in place polyurethane.
- Recessed, stainless steel ledge provided for supporting pans, adaptor bars included.
- Mechanical parts are easily accessible for quick servicing & maintenance.
- Designed to adapt to GN 1/1 or 1/2 pans or 1/3 pans in either 100mm and/or 150mm depths in each well (pan NOT included).

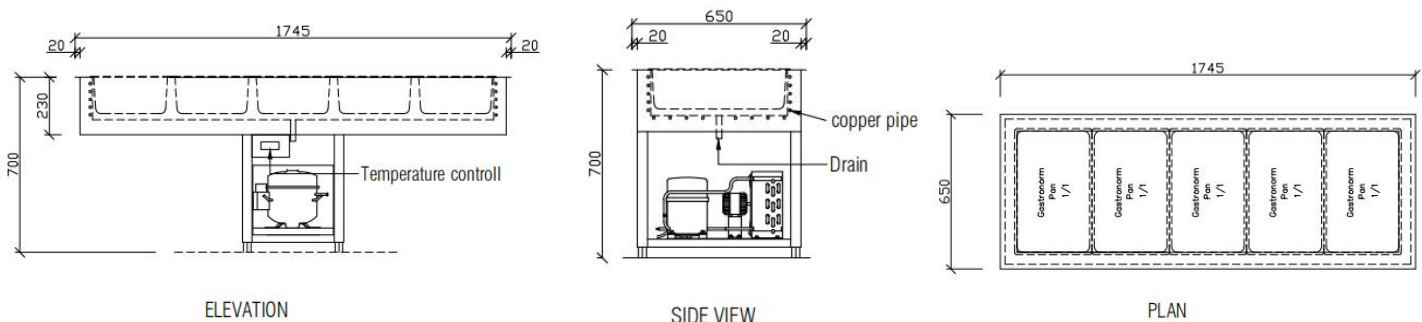

Note: Remote refrigeration system for the cold food drop-in well(s) is also available upon request.



Technical Specifications

Model	Pan / Product Capacity	Voltage	Phase	Cycle	Amps	Watts	Cord Length
DS-CW-V5	Five GN 1/1 pan; Ten GN 1/2 pans; Fifteen GN 1/3 pans; (all in either 100mm or 150mm depth per well) 17 kg product maximum; 21L volume maximum.	220V	1	50Hz	10	1.2	900mm

Dimensions & Weights

Interior Dimensions (W x D x H in mm)	Exterior Dimensions (W x D x H in mm)	Product Net Weight (kg)	Shipping Dimensions with Wooden Crating (W x D x H in mm)	Shipping Weight with Wooden Crating (kg)
1648 x 556 x 222	1745 x 650 x 700	145	1890 x 800 x 950	168

INSTALLATION REQUIREMENTS

- The countertop must be water resistant.
- Equipment must be installed level and must not be installed in any area where it may be affected by steam, grease, dripping water, extreme temperatures, or any other severely adverse conditions.
- Equipment must not be installed under a hood.
- Avoid installing appliance under a 4-way ceiling diffuser.
- Outdoor use is not recommended.
- A water drain or water catch basin is required for appliance.
- LED lighting is recommended for overhead lighting.

CLEARANCE REQUIREMENTS

- 30mm from combustible surfaces.

Note: Three (3) years international warranty on parts.



DK Resources International Ltd

Marketed & Distributed by:

DK Resources International Ltd.

Tel: +852 68906866; +65 90180938; Fax: +65 62342036

E-mail: dss168@hotmail.com; dss-sales168@hotmail.com; dannyk88@singnet.com.sg

Due to ongoing product improvement, specifications are subject to change without prior notice